

AVIATOR S Series. SMART FLEET™.
Smart business.

COBHAM

The most important thing we build is trust



Next generation satcom solutions
for a **more connected and
profitable** airline.

Smart product.

Smaller, lighter, better.

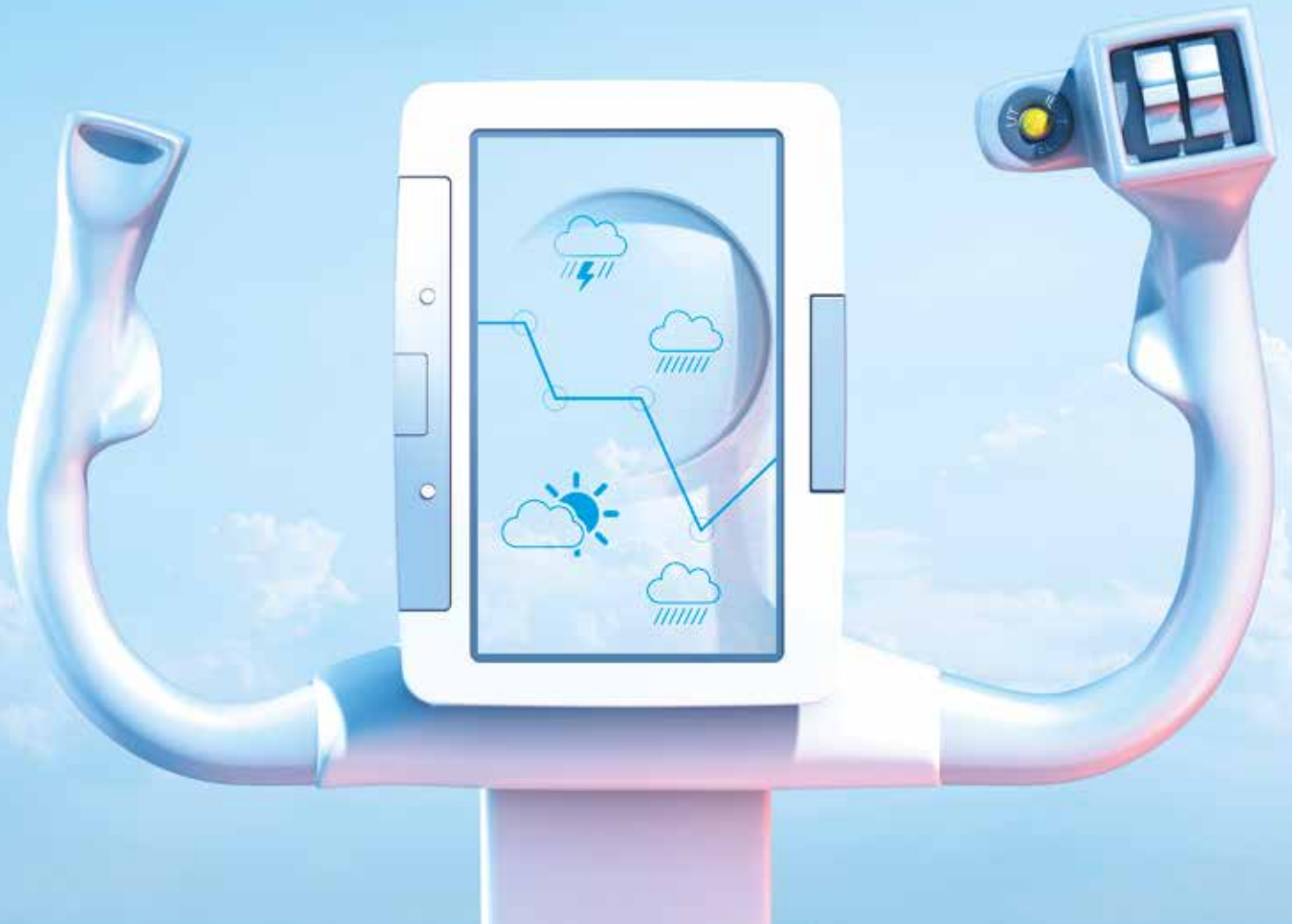

AVIATOR S Series brings next generation connectivity to commercial aviation. Not only does it enable Safety Services over SwiftBroadband, but it links your organisation for intelligent fleet management and efficient operations – all in a smaller, lighter and smarter package.

Inmarsat SwiftBroadband has given rise to the IP-enabled flight deck, introducing a wide range of sophisticated solutions that increase communication and capability across Air Traffic Control, Aircraft Operational Control and cabin crew operations.

With AVIATOR S Series from Cobham SATCOM, you can now enable these next generation technologies and standards for faster, more reliable connectivity across your entire organisation. By sharing more – and more complex – data in real time, you can make better informed decisions to enhance operational efficiency, reduce your fleet's satellite airtime costs and contribute to improved yield per passenger mile.





Smaller size - lower cost

AVIATOR S Series delivers ACARS services over a robust IP data link as well as multiple voice channels. It is smaller, lighter and has a lower cost of ownership than any other Inmarsat system, including lower airtime costs.

The system's compact design is suitable for all single-aisle and wide-bodied aircraft. It is faster to install and configure, compatible with all Inmarsat L-band antenna systems and, in the case of AVIATOR 200S, it reduces the number of LRUs down to 2, saving on space and weight, and reducing fuel burn.

Passenger Information and Entertainment Services (PIES)

- Cabin crew voice and data communication
- Credit card validation

The entire AVIATOR S Series product portfolio is compatible with all classes of Inmarsat SwiftBroadband services: Class 4 (AVIATOR 200S), Class 6 (AVIATOR 700S) and Class 7 (AVIATOR 600S). All our systems meet requirements for FANS 1/A operations.

Highly secure, separate domains

Built to Cobham's uncompromising standards, AVIATOR S Series' architecture allows for secure aircraft domain segregation with priority for the Aircraft Control Domain (ACD) over the Aircraft Information Service Domain (AISD) and the Passenger Information & Entertainment Services domain (PIES).

Aircraft Information Service Domain (AISD)

- Electronic Flight Bag
- Streaming of flight data, including engine monitoring

Complete segregation between the three domains ensures absolute data security and meets all data communications specifications according to the standards of ARINC 781, Attachment 8.

- Ultra-compact Cobham SATCOM HELGA antenna and C-SDU two-box solution for a total system weight of less than 8kg (17.6lbs) in the AVIATOR 200S configuration
- Low power requirements consuming less than 130 watts
- Data segregation between safety and non-safety domains
- FANS 1/A compliant
- Multiple simultaneous voice calls
- Reduced LRUs to only 2 in AVIATOR 200S
- Meets all ARINC 781 specifications



Aircraft Control Domain (ACD)

- CPDLC, ADS-C - FANS 1/A
- Multiple voice channels
- ACARS

HELGA (HLD & Enhanced Low Gain Antenna)

- Diplexer Low Noise Amplifier (DLNA) and High Power Amplifier (HPA) built into the antenna
- Complies with ARINC 741 LGA (Low Gain Antenna) mounting footprint requirements
- Unique 4th generation phased array technology



C-SDU (Compact Satellite Data Unit)

- 2 MCU LRU with an ARINC 600 connector
- Supports up to 2 SwiftBroadband channels for ACARS, IP data and multiple voice capabilities according to ARINC 781 Attachment 7
- Complete aircraft network segregation



MCHPA (Multi-Channel HPA)

- 2MCU LRU with an ARINC 600 connector
- Highly linear HPA for multiple SwiftBroadband channels
- Allows use of all Cobham SATCOM's HGA and IGA antennas



Smart aircraft.

Unlock valuable flight diagnostics and data.



AVIATOR S Series enables pilots to share real-time, relevant information with dispatchers and ground control for greater safety, situational awareness, route optimisation and to sync aircraft with your Flight Operations Quality Assurance (FOQA) system.



Each flight generates vast amounts of valuable data that can be shared to optimise fleet operations. With AVIATOR S Series, you can take full advantage of powerful Aircraft Health Monitoring (AHM) applications designed to facilitate fleet management and analyse trending of flight parameters.

The result is a secure and segregated system of AHM and FOQA, allowing maintenance crews to identify trends and investigate the circumstances behind all flagged events - invaluable information to enhance safety and maintenance procedures in the air and on the ground. You can also enable powerful next generation Electronic Flight Bag (EFB)



applications to optimise route planning and improve flight tracking.

Real-time EFB data

With secure ‘always on’ communications between crew, ground operations and ATC, AVIATOR S Series enables pilots to take advantage of purpose-built EFB flight management applications, giving them a wealth of information to improve efficiency, safety and situational awareness.

For example, by accessing live weather data such as turbulence and thunderstorms, pilots can make appropriate and intelligent adjustments to flight plans in real time.

With a complete 3D overview, pilots can take the most efficient route, minimising fuel burn by avoiding diversions and reducing the potential for aircraft damage - or cabin crew and passenger injury.

Reduce aircraft downtime

The automatic transmission of key flight data is invaluable to help optimise aircraft maintenance programmes and reduce aircraft downtime.

With AVIATOR S Series you can actively monitor aircraft parameters, such as Aircraft Health Monitoring, helping ground teams to stay one step ahead with prompt problem resolution, real-time analysis and predictive maintenance programmes - all contributing to a lower average ground turnaround time.

Connected Electronic Flight Bag

- 3D overview of weather conditions
- Up-to-the-minute decision making
- Continuous communications between pilots, dispatchers and ground maintenance crews
- Route optimisation for higher yield per mile
- Passenger services and crew management
- Flight data information streamed from the aircraft
- Updated NOTAMs



SMART FLEET™.

A more intelligent, safer and profitable organisation.



The FANS 1/A-compliant AVIATOR S Series next generation satcom solution turns your fleet into a SMART FLEET™. This means a more connected, intelligent and safer organisation with better-informed decision making from top to bottom – and an airline built for the future.

The real advantages of AVIATOR S Series are best understood at a fleet-wide level. This is where faster, more reliable connectivity, an e-enabled crew and real-time information sharing delivers significant commercial value with greater cost savings, improved safety procedures and increased ancillary revenue.

Real-time flight planning

AVIATOR S Series enables satcom connectivity, giving dispatchers complete situational awareness on fleet movements as well as the conditions under which they are operating. In this way, the flight plan is no longer static but is instead dynamically linked to fleet and weather conditions,

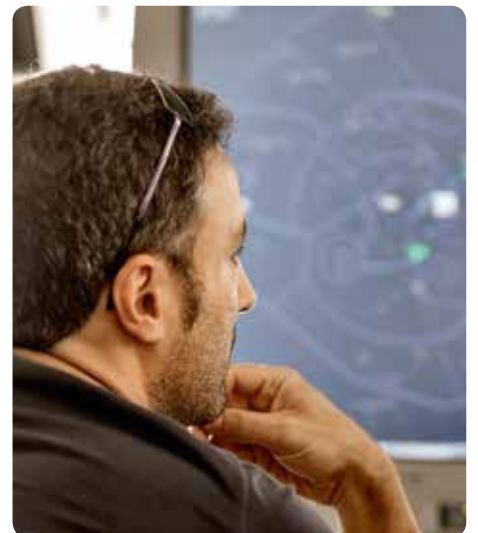



enabling dispatchers to make adjustments to flight plans in real time.

In addition, with a fast, reliable and secure IP data connection, dispatchers and pilots have the same information at hand at the same time, making it easier to consolidate and synchronise vital flight management decisions.

Increase ancillary revenue

A faster, secure data connection also enables you to upgrade cabin crew applications. This is crucial to ensure a more seamless passenger experience and to help drive ancillary revenue.

On one hand, cabin crews can be better prepared with important flight information such as delays and special requirements while passengers receive up-to-the-minute updates on connecting flights, re-booking, baggage and gate information. On the other, your airline benefits from faster and more reliable credit card payments for food, duty-free and other in-flight transactions.

An airline built for the future

AVIATOR S Series transforms your airline into a business that is not only one step ahead of the challenges you face today, but one that is able to take full advantage of new communications and data-sharing applications as they continue to expand in versatility and value.

By enhancing the accuracy, deployment and presentation of information between aircraft and ground control; by improving the speed and quality of management decisions; and by creating a more proactive and well-prepared maintenance operation, you can make sure your fleet - and your business - is primed and ready for the future.



To upgrade your fleet to SMART FLEET™ visit www.cobham.com/satcom/aviator-s or contact us at satcom.aviator@cobham.com



AVIATOR S Series – SMART FLEET™

Cobham SATCOM's AVIATOR S Series gives you a SMART FLEET™ by enabling next generation fleet management and optimising fleet operations – all in a smaller, lighter and smarter package.

Configurations

AVIATOR 200S (Class 4 system)

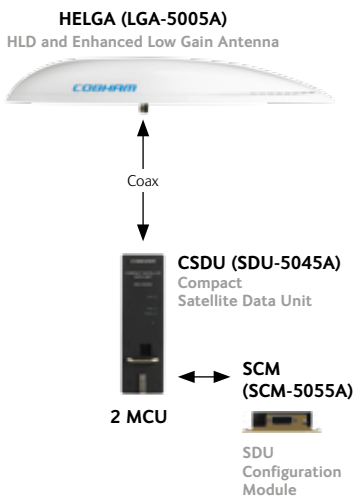

AVIATOR 600S (Class 7 system)

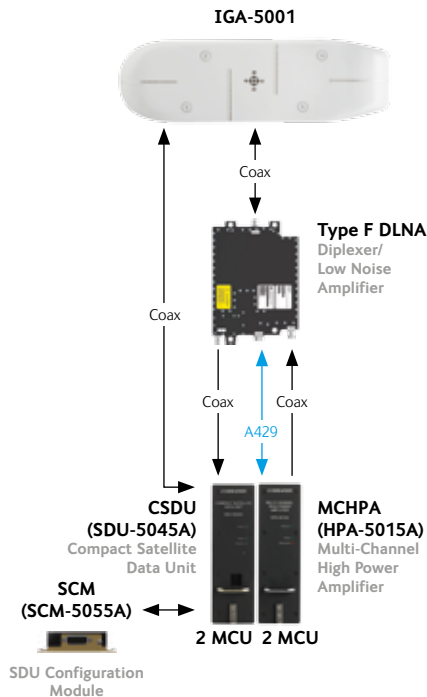

AVIATOR 700S (Class 6 system)

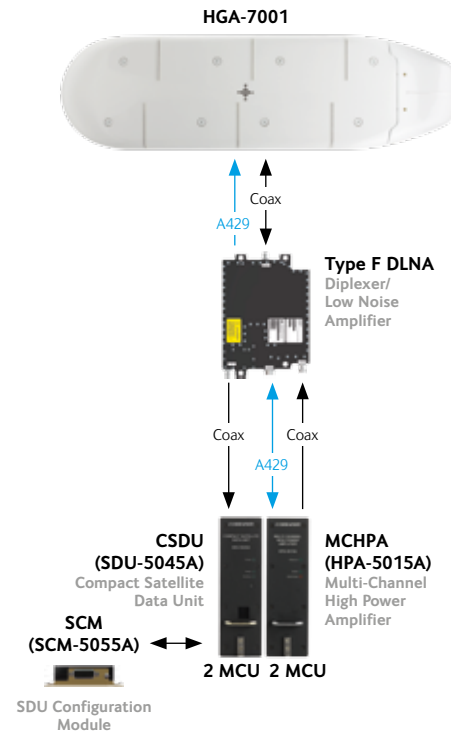

The most important thing we build is trust